

# 单一窗口客户端导入接口说明

(草稿)

## 一、概述

此文档用于说明企业通过单一窗口平台自动导入的对接及使用，目前支持的业务有：

序号	业务	可用环境
1.	货物申报，报关单导入暂存	联调测试 运行（20170830）
2.	舱单申报，导入申报	联调测试 运行（20170830）

## 二、系统环境

### 支持的操作系统

Windows 7, Windows 7 Service Pack 1, Windows Server 2008, Windows Server 2008 R2, Windows Server 2008 R2 SP1

- Windows 7
- Windows Server 2008 R2（在服务器核心角色上不受支持）
- Windows 7 SP1
- Windows Server 2008 R2 SP1
- 支持的体系结构：
  - x86
  - x64

### 必备组件：

- Windows Installer 4.5 或更高版本
- Internet Explorer 10 或更高版本
- Microsoft .NET Framework 4

<https://www.microsoft.com/zh-cn/download/details.aspx?id=17718>

- 卡控件——EportlkeySetup\_VXXX.exe

下载地址：<https://app.singlewindow.cn/cas/login> 页面右下角“卡控件下载”，如图所示



### 三、 文件导入说明

#### 1) 数据交换目录规范

<BizID>

- OutBox: 待发送文件目录
- SentBox: 发送完毕的文件
- InBox :
  - 回执文件
  - 发送处理结果的说明文件
  - 校验失败说明文件
- FailBox: 服务端校验失败的文件

说明:

根目录可配置, BizID 为业务别名, 如货物申报为 DEC、舱单为 MFT 等;

FailBox 目录为报文错误、业务逻辑错误而发送失败的文件; 因网络、服务或程序引起的失败会留在 OutBox 目录下进行自动重试。

#### 2) 文件命名规范

目前可以接收.zip 文件或.xml 文件，其中：当一票报文不包含无纸化随附单据，可直接传输结构化报文（格式为 XML 文件）；当一票报文中包含无纸化随附单据时，需以 ZIP 包方式导入，ZIP 包中必须包含结构化报文 XML 文档和对应的所有随附单据（格式为 PDF 文件）。企业导入文件时应保证文件名称的唯一性，否则将被覆盖。

- 文件写入过程

- a) 先建立.Temp 扩展名的文件进行数据写入；
- b) 在数据全部写入完毕后，修改文件名为 .zip 或.xml
- c) 发送监控程序只处理 .zip 或.xml 扩展名的文件

### 3) 清理规则

- OutBox：文件发送成功移动到 SentBox，失败移动到 FailBox
- SentBox：每次客户端启动时清理过期文件，或按照用户设置
- InBox：由企业系统处理
- FailBox：由企业系统处理

## 四、 接口说明

### 报文格式:

采用 XML 格式

### 字符编码:

```
<?xml version="1.0" encoding="UTF-8"?>
```

### 报文标准如下:

企业导入客户端使用 XML 格式作为数据交换文件，分为 Head 和 Data 两部分，Head 部分用于客户端处理使用的信息，Data 部分实际业务导入报文。

报文结构暂定如下，试点期间有可能按需要进行调整。



SWDataImpClient-20170817.xsd

## （一）导入发送报文说明

### 1) 报文结构

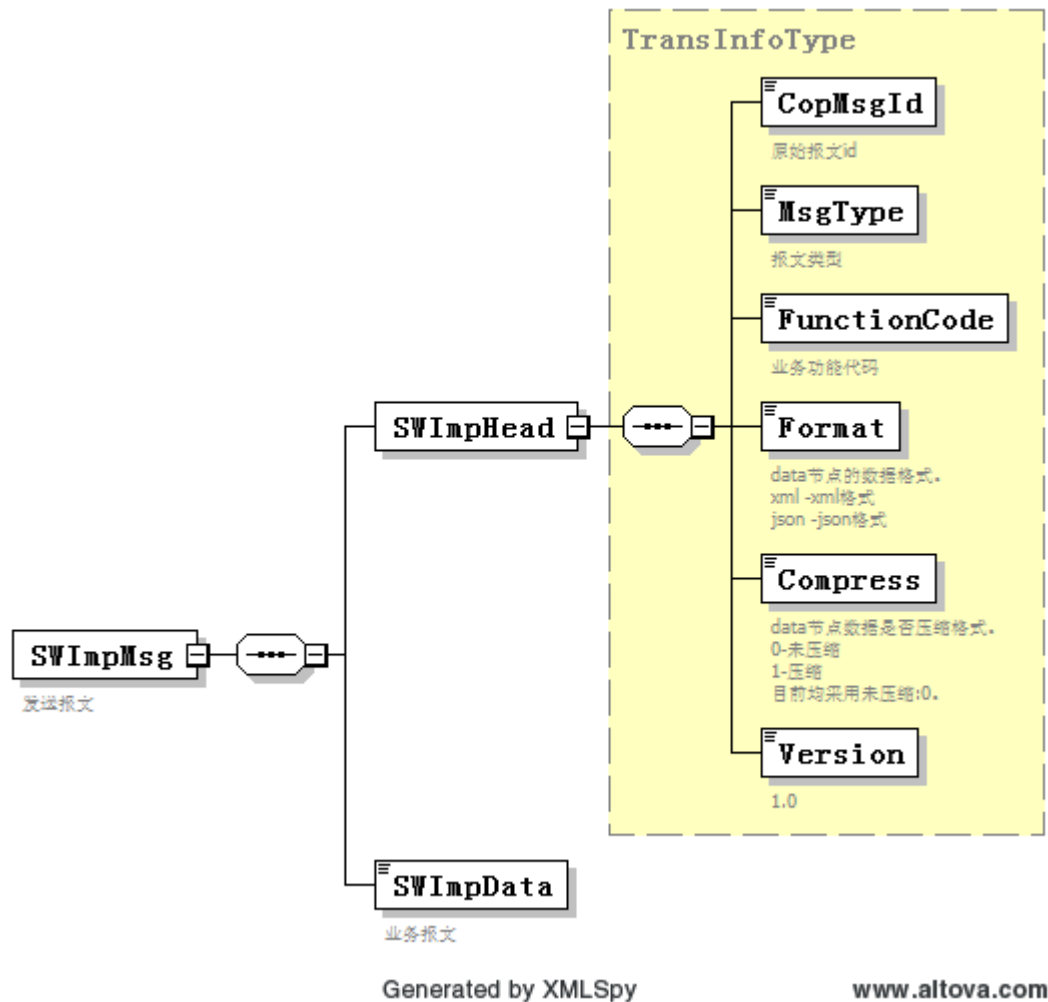

## 2) 报文定义

```

<?xml version="1.0" encoding="UTF-8"?>
<SWImpMsg xmlns:xsi="http://www.w3.org/2001/XMLSchema-instance">
  <SWImpHead>
    <CopMsgId>企业报文物理文件名</CopMsgId>
    <MsgType>业务报文类型</MsgType>
    <FunctionCode>业务功能代码</FunctionCode>
    <Format>Data节点数据格式说明</Format>
    <Compress>是否压缩</Compress>
    <Version>服务版本号</Version>
  </SWImpHead>
  <SWImpData>业务报文</SWImpData>
</SWImpMsg>

```

## 3) 报文字段说明

表 1 发送报文的接口

序号	字段代码名称	字段中文名称	参数定义	说明
1.	CopMsgId	原始报文文件名		
2.	MsgType	报文类型	业务报文类型定义	见 MsgType 定义
3.	FunctionCode	业务功能代码		见 FunctionCode 定义
4.	Format	请求报文数据格式	xml -xml 格式 json -json 格式	data 节点的数据格式。 data 节点为 16 号公告的，此字段传 xml
5.	Compress	是否压缩	0-未压缩 1-压缩	data 节点数据是否压缩格式。 目前均采用未压缩:0。
6.	Version	版本说明	版本 1.0	
7.	Data	业务报文		业务报文数据 货物申报报关单、舱单申报为海关 16 号公告节点； 报文说明参见 <a href="http://www.chinaport.gov.cn/gg/zgdzksajzx/16009.htm">http://www.chinaport.gov.cn/gg/zgdzksajzx/16009.htm</a> 在线报文检查工具： <a href="http://bulletin16.test.chinaport.gov.cn/formatcheck16/">http://bulletin16.test.chinaport.gov.cn/formatcheck16/</a>

## MsgType 定义

业务	代码	说明
货物申报	SWDEC001	报关申报
舱单申报	MT1101	进口水运原始舱单
	MT2101	出口水运预配舱单
	MT3101	水运出口运抵
	MT3102	水运分流运抵
	MT4101	水运装载舱单
	MT5101	水运进口理货
	MT5102	水运出口理货
	MT6101	水运分流
	MT6102	水运分拨
	MT7101	水运装箱清单
	MT8101	水运进口改靠港
	MT8102	水运出口落装
	MT8103	水运出口落装改配
	MT8104	水运出口直接改配
	MT8105	水运国际转运准单

## FunctionCode 定义

业务	代码	说明
货物申报	G	暂存
舱单申报	2	新增
	3	删除申请
	5	变更申请
	9	主要数据新增
	0	其他数据新增
	11	通关回执
	注：主要数据新增和其他数据新增仅用于原始舱单和预配舱单，其他单证的新增申报使用“2-新增”。	

## (二) 导入回执报文说明

### 1) 报文结构

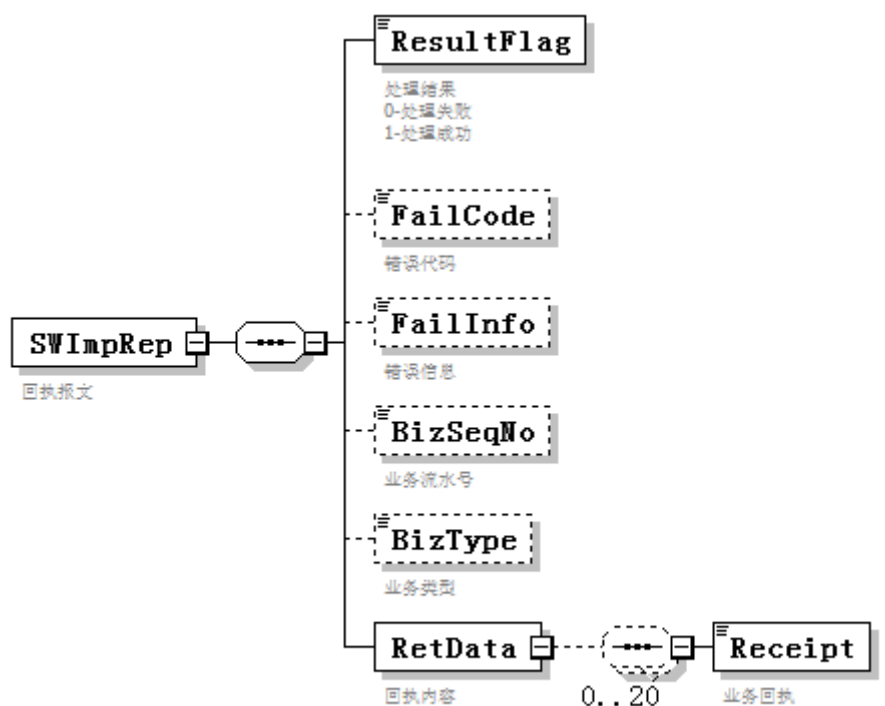

Generated by XMLSpy

www.altova.com

### 2) 报文定义

详见 SWDataImpClient-YYMMDD.xsd

### 3) 报文字段说明

表 2 回执报文的接口

序号	字段代码名称	字段中文名称	参数定义	说明
1.	ResultFlag	处理结果	0-处理失败 1-处理成功	
2.	FailCode	错误代码		ResultFlag 为 0 时，返回错误代码。
3.	FailInfo	错误信息		ResultFlag 为 0 时，返回错误信息
4.	BizSeqNo	业务流水号		业务回执报文有此字段 如：货物申报为关检关联号，舱单申报为 messageID
5.	BizType	报文类型		业务回执报文有此字段，对应 messageType
6.	RetData	返回数据		ResultFlag 为 1 时，返回处理结果报文。

错误代码分类说明：

表3 错误代码

	错误代码	备注
服务端错误代码	00	系统内部错误
	01	报文解析错误
	02	SQL 执行错误
	03	SQL 执行超时
	04	SQL 查询为空
	05	错误参数
	06	非法用户
	07	非法授权
	08	非法 IP
客户端错误代码	C00	内部错误
	C01	文件解析错误
	C02	报文格式检查不通过
	C03	报文逻辑检查不通过

	C04	报文预处理失败
	C05	报文签名失败
	C06	报文转换失败
	C07	报文发送失败
	C08	报文发送结果处理失败
	C09	回执查询失败
	C10	回执解析失败
	C11	回执接收失败
	C12	xsd 校验不通过
	C13	pdf 文件校验异常
	C131	pdf 文件不存在
	C132	pdf 单个文件大小校验不通过
	C133	PDF 平均每页大小校验不通过
	C134	PDF 文件加签失败
	C135	PDF 文件加签异常
	C136	PDF 文件上传失败
	C137	PDF 文件上传异常
	C14	卡操作异常
	C141	开卡失败
	C142	关卡失败
	C143	卡密码校验失败

#### 4) 回执文件命名规范

回执分为 3 类，发送成功回执、发送失败回执、后续业务回执。

**发送成功**回执文件命名方式：“Succesed\_”+ CopMsgId + “(” + MsgType + “\_” + FunctionCode ++ “.xml”

如：Succesed\_test05 转关提前报关 pdf(SWDEC001\_0).xml

**发送失败**回执文件命名方式：“Failed\_”+ CopMsgId + “(” + MsgType + “\_” + FunctionCode ++ “.xml”

如：Failed\_test05 转关提前报关 pdf(SWDEC001\_0)

后续**业务回执**文件命名方式：



报关单：“Receipt\_”+ 关键关联号 cusCiqNo + “\_” + YYYYMMDDhhmmssfff + “.xml”

如：Receipt\_E2017000000007834\_20170825092947361.xml

舱单：“Receipt\_”+ MessageId + “\_” + YYYYMMDDhhmmssfff + “.xml”

如：Receipt\_CN\_MT4101\_1p1\_4201101115245\_20170823102241559\_20170823101654212

## 五、 报文示例

### (一) 报关单导入报文

导入暂存报文示例：

```
<?xml version="1.0" encoding="UTF-8"?>
<!--Sample XML file generated by XMLSpy v2013 (http://www.altova.com)-->
<ImportMessage xsi:noNamespaceSchemaLocation="SWImportMessagexsd.xsd"
xmlns:xsi="http://www.w3.org/2001/XMLSchema-instance">
  <Head>
    <CopMsgId>普通报关单.xml</CopMsgId>
    <MsgType>SWDEC001</MsgType>
    <FunctionCode>0</FunctionCode>
    <Format>xml</Format>
    <Compress>0</Compress>
    <Version>1.0</Version>
  </Head>
  <Data>
    <DecMessage>
      <DecHead>
        <SeqNo/>
        <PreEntryId/>
        <ManualNo/>
        <CustomMaster>0100</CustomMaster>
        <IEPort>0102</IEPort>
        <BillNo/>
        <TrafMode>9</TrafMode>
        <TrafName/>
        <PayWay>2</PayWay>
        <TradeCode>1101919107</TradeCode>
        <TradeName>中国山货花卉进出口公司</TradeName>
        <OwnerCode>1101919107</OwnerCode>
        <OwnerName>中国山货花卉进出口公司</OwnerName>
        <AgentCode>1101919107</AgentCode>
        <AgentName>中国山货花卉进出口公司</AgentName>
        <DistrictCode>37065</DistrictCode>
        <TradeCountry>142</TradeCountry>
        <PaymentMark/>
      </DecHead>
    </DecMessage>
  </Data>
</ImportMessage>
```

<TradeMode>5100</TradeMode>  
<DistinatePort>142</DistinatePort>  
<TransMode>1</TransMode>  
<CutMode/>  
<FeeMark/>  
<FeeRate/>  
<FeeCurr/>  
<LicenseNo>22-33-888899</LicenseNo>  
<InsurMark/>  
<InsurRate/>  
<InsurCurr/>  
<OtherMark>1</OtherMark>  
<OtherRate>0.0002</OtherRate>  
<OtherCurr>142</OtherCurr>  
<WrapType>7</WrapType>  
<PackNo>12</PackNo>  
<GrossWet>39</GrossWet>  
<NetWt>17</NetWt>  
<NoteS>ZCF测试esb导入</NoteS>  
<ApprNo>jiehuizhenghao</ApprNo>  
<ContrNo>2010-04-6</ContrNo>  
<InRatio>1</InRatio>  
<EntryType>M</EntryType>  
<IEDate/>  
<IEFlag>I</IEFlag>  
<AgentLinkMan>1</AgentLinkMan>  
<AgentLinkMAIL>na.n.lee@foxconn.com</AgentLinkMAIL>  
<AgentLinkPHONE>2222-2168000-79588</AgentLinkPHONE>  
<OwnerLinkMan/>  
<OwnerLinkMAIL/>  
<OwnerLinkPHONE/>  
<Type>CL</Type>  
<EntryId/>  
<EdiId>1</EdiId>  
<Risk/>  
<CopName>中国山货花卉进出口公司</CopName>  
<CopCode>101115245</CopCode>  
<PDate/>  
<TypistNo>000000009759</TypistNo>  
<InputerName>zcf</InputerName>  
<InputerNameMAIL/>  
<InputerNamePHONE/>  
<PartenerID/>  
<TgdNo/>

```
<DataSource/>
<DeclTrnRel>0</DeclTrnRel>
<BillType/>
<AgentCodeScc>AAAAAAAA1105910159</AgentCodeScc>
<OwnerCodeScc>AAAAAAAA1105910159</OwnerCodeScc>
<TradeCodeScc>AAAAAAAA1105910159</TradeCodeScc>
<CopCodeScc>AAAAAAAA1105910159</CopCodeScc>
<PromiseItmes>0011</PromiseItmes>
<TradeAreaCode>502</TradeAreaCode>
</DecHead>
<DeclLists>
  <DeclList>
    <GNo>1</GNo>
    <ContrItem>2</ContrItem>
    <CodeTS>8407310000</CodeTS>
    <GName>gname|1</GName>
    <GModel/>
    <FirstQty>17</FirstQty>
    <FirstUnit>001</FirstUnit>
    <GQty>100</GQty>
    <GUnit>001</GUnit>
    <SecondQty>1</SecondQty>
    <SecondUnit>061</SecondUnit>
    <OriginCountry>110</OriginCountry>
    <TradeCurr>502</TradeCurr>
    <DeclPrice>10</DeclPrice>
    <WorkUsd/>
    <UseTo>01</UseTo>
    <ExgNo>111</ExgNo>
    <DutyMode>3</DutyMode>
    <ClassMark/>
    <Factor/>
    <DeclTotal>1000</DeclTotal>
    <ExgVersion>1</ExgVersion>
    <DestinationCountry>142</DestinationCountry>
  </DeclList>
  <DeclList>
    <GNo>2</GNo>
    <ContrItem>2</ContrItem>
    <CodeTS>8407310000</CodeTS>
    <GName>gname|1</GName>
    <GModel/>
    <FirstQty>17</FirstQty>
    <FirstUnit>001</FirstUnit>
```

```
<GQty>100</GQty>
<GUnit>001</GUnit>
<SecondQty>12</SecondQty>
<SecondUnit>061</SecondUnit>
<OriginCountry>110</OriginCountry>
<TradeCurr>502</TradeCurr>
<DeclPrice>10</DeclPrice>
<UseTo/>
<DutyMode>3</DutyMode>
<ClassMark/>
<Factor/>
<DeclTotal>1000</DeclTotal>
<WorkUsd/>
<ExgNo/>
<ExgVersion>1</ExgVersion>
<DestinationCountry>142</DestinationCountry>
</DecList>
<DecList>
  <GNo>3</GNo>
  <ContrItem>4</ContrItem>
  <CodeTS>2710191100</CodeTS>
  <GName>gname|1|</GName>
  <GModel/>
  <FirstQty>17</FirstQty>
  <FirstUnit>035</FirstUnit>
  <GQty>100</GQty>
  <GUnit>035</GUnit>
  <SecondQty>12</SecondQty>
  <SecondUnit>095</SecondUnit>
  <OriginCountry>110</OriginCountry>
  <TradeCurr>110</TradeCurr>
  <DeclPrice>10</DeclPrice>
  <UseTo/>
  <DutyMode>3</DutyMode>
  <ClassMark/>
  <Factor/>
  <DeclTotal>1000</DeclTotal>
  <WorkUsd/>
  <ExgNo/>
  <ExgVersion>1</ExgVersion>
  <DestinationCountry>142</DestinationCountry>
</DecList>
</DecLists>
<DecContainers>
```

```
<Container>
  <ContainerId>12345678901</ContainerId>
  <ContainerMd>S</ContainerMd>
  <ContainerWt>1.1</ContainerWt>
</Container>
</DecContainers>
<DecLicenseDocus>
  <LicenseDocu>
    <DocuCode>U</DocuCode>
    <CertCode>201412345678:1</CertCode>
  </LicenseDocu>
</DecLicenseDocus>
<DecFreeTxt>
  <RelId>010420121001444111</RelId>
  <RelManNo/>
  <BonNo>222</BonNo>
  <DecBpNo>111</DecBpNo>
  <CusFie/>
  <DecNo/>
  <VoyNo/>
</DecFreeTxt>
<DecSign>
  <OperType>C</OperType>
  <ICCode>8950000038768</ICCode>
  <CopCode>101115245</CopCode>
  <OperName>ceshi16</OperName>

  <Sign>TRJAidneO2/Tlz2THNUnr+NQNK3pigG40MY2d9nySmHia1Jf2vy/nN53eGKHE6pVv0OuDVJyZd
  QIH2/anZwgGUSJfQUBbKAGPR6shBDbHdgSMwpXDH91QudqxCyZVQOWCl6AwIZL+GjeE3Gihpo1kJj7IhA
  3Dt9YVywkaO56YCE=</Sign>
  <SignDate>2011072210050002</SignDate>
  <ClientSeqNo>decnew201707127788</ClientSeqNo>
  <Certificate>4d057d</Certificate>
  <HostId/>
</DecSign>
<EcoRelation>
  <CertType>Y19</CertType>
  <EcoCertNo>K001-16-0636799</EcoCertNo>
  <DecGNo>1</DecGNo>
  <EcoGNo>1</EcoGNo>
  <ExtendFiled/>
</EcoRelation>
</DecMessage>
</Data>
```

```
</ImportMessage>
```

## 导入成功回执示例

```
<?xml version="1.0" encoding="UTF-8"?>
<Root>
  <resultFlag>1</resultFlag>
  <failCode/>
  <failInfo/>
  <retData>{"responseMessage":"暂存成功!
", "responseCode": "1", "cusCiqNo": "I20170000000007702", "preEntryId": ""}</retData>
</Root>
```

## 导入失败回执示例

```
<?xml version="1.0" encoding="UTF-8"?>
<Root>
  <resultFlag>0</resultFlag>
  <failCode>C134</failCode>
  <failInfo>[ { "assono": "普通报关单8pdf-3M-2.xml", "filePath":
"D:\\[Release]\\data\\ImpTemp\\DEC\\普通报关单8pdf-3M_3\\", "filesInfo": [ { "fileName":
"2017082421270000211673.pdf", "status": " -1", "pdfInfo": "方正组件访问临时目录错误!" },
{ "fileName": "2017082421270000211675.pdf", "status": " -1", "pdfInfo": "方正组件访问临时目录
错误!" }, { "fileName": "2017082421270000211677.pdf", "status": " -1", "pdfInfo": "方正组件访
问临时目录错误!" }, { "fileName": "2017082421270000211679.pdf", "status": " -1", "pdfInfo": "
方正组件访问临时目录错误!" }, { "fileName": "2017082421270000211681.pdf", "status": " -1",
"pdfInfo": "方正组件访问临时目录错误!" }, { "fileName": "2017082421270000211683.pdf", "status":
" -1", "pdfInfo": "方正组件访问临时目录错误!" }, { "fileName": "2017082421270000211685.pdf",
"status": " -1", "pdfInfo": "方正组件访问临时目录错误!" }, { "fileName":
"2017082421270000211687.pdf", "status": " -1", "pdfInfo": "方正组件访问临时目录错
误!" } ] } ]</failInfo>
  <retData/>
</Root>
```

## 报关单业务回执报文示例

```
<?xml version="1.0" encoding="utf-8"?>
<SWImpRep>
  <ResultFlag>1</ResultFlag>
  <FailCode/>
  <FailInfo/>
  <BizSeqNo>E20170000000008667</BizSeqNo>
  <BizType>SWDEC101</BizType>
  <RetData>
    <Receipt>
      <CusCiqNo>E20170000000008667</CusCiqNo>
```

```
<NoticeDate>2017-04-27 21:24:09</NoticeDate>
<Channel>2</Channel>
<Note>海关预录入接收已成功! </Note>
<CustomMaster>0100</CustomMaster>
<IEDate>2017-04-25 00:00:00</IEDate>
<DDate>2017-04-27 00:00:00</DDate>
</Receipt>
<Receipt>
<CusCiqNo>E20170000000008667</CusCiqNo>
<NoticeDate>2017-04-27 21:22:52</NoticeDate>
<Channel>7</Channel>
<Note>Z1100000472114160直接申报成功</Note>
</Receipt>
<Receipt>
<CusCiqNo>E20170000000008667</CusCiqNo>
<NoticeDate>2017-04-27 21:23:22</NoticeDate>
<Channel>7</Channel>
<Note>2017042721240 发往海关E010000H2K01002017042721250000140501352. DEC</Note>
</Receipt>
<Receipt>
<CusCiqNo>E20170000000008667</CusCiqNo>
<NoticeDate>2017-04-27 21:30:40</NoticeDate>
<Channel>E</Channel>
<Note>退单或入库失败;申报方式有误:4</Note>
<IEDate>2017-04-25 00:00:00</IEDate>
</Receipt>
<Receipt>
<CusCiqNo>E20170000000008667</CusCiqNo>
<NoticeDate>2017-04-27 21:31:11</NoticeDate>
<Channel>2</Channel>
<Note>海关预录入接收已成功! </Note>
<CustomMaster>0100</CustomMaster>
<IEDate>2017-04-25 00:00:00</IEDate>
<DDate>2017-04-27 00:00:00</DDate>
</Receipt>
<Receipt>
<CusCiqNo>E20170000000008667</CusCiqNo>
<NoticeDate>2017-04-27 21:29:56</NoticeDate>
<Channel>Y</Channel>
<Note>状态不对</Note>
</Receipt>
</RetData>
</SWImpRep>
```

## (二) 舱单导入报文

舱单导入报文示例:

```
<?xml version="1.0" encoding="UTF-8"?>
<!--Sample XML file generated by XMLSpy v2013 (http://www.altova.com)-->
<ImportMessage xsi:noNamespaceSchemaLocation="SWImportMessagexsd.xsd"
xmlns:xsi="http://www.w3.org/2001/XMLSchema-instance">
  <SWImpHead>
    <CopMsgId>MT2101-9水运预配舱单（主要数据新增）.xml</CopMsgId>
    <MsgType>MT2101</MsgType>
    <FunctionCode>9</FunctionCode>
    <Format>xml</Format>
    <Compress>0</Compress>
    <Version>1.0</Version>
  </SWImpHead>
  <SWImpData>
    <Manifest xmlns="urn:Declaration:datamodel:standard:CN:MT2101:1">
      <Head>
        <MessageID>CN_MT2101_1p1_0000741852969_20170408023234938</MessageID>
        <FunctionCode>9</FunctionCode>
        <MessageType>MT2101</MessageType>
        <SenderID>4201101115245_SWS0000000001</SenderID>
        <ReceiverID>EPORT</ReceiverID>
        <SendTime>20170408023234938</SendTime>
        <Version>1.0</Version>
      </Head>
      <Declaration>
        <RepresentativePerson>
          <Name>4201101115245</Name>
        </RepresentativePerson>
        <ExitCustomsOffice>
          <ID>CNAJG/4201</ID>
        </ExitCustomsOffice>
        <Agent>
          <ID>4201101115245</ID>
        </Agent>
        <Carrier>
          <ID>APL</ID>
        </Carrier>
        <BorderTransportMeans>
          <JourneyID>NFHA0628006</JourneyID>
          <TypeCode>1</TypeCode>
          <ID>YS0418</ID>
          <Name>YS0418</Name>
        </BorderTransportMeans>
      </Declaration>
    </Manifest>
  </SWImpData>
</ImportMessage>
```



```
<FirstArrivalLocationID>RSCRG</FirstArrivalLocationID>
<ArrivalDateTime>20170414083112</ArrivalDateTime>
<DepartureDateTime>20170406033226</DepartureDateTime>
</BorderTransportMeans>
<Consignment>
  <TransportContractDocument>
    <ID>NFHA062800101</ID>
    <ConditionCode>27</ConditionCode>
    <Consolidator>
      <ID>32</ID>
    </Consolidator>
  </TransportContractDocument>
  <GrossVolumeMeasure>232</GrossVolumeMeasure>
  <ValueAmount CurrencyTypeCode="AED">232</ValueAmount>
  <LoadingLocation>
    <ID>CNAJG/4201</ID>
    <LoadingDate>20170425133613</LoadingDate>
  </LoadingLocation>
  <UnloadingLocation>
    <ID>RSCBO</ID>
    <ArrivalDate>20170413</ArrivalDate>
  </UnloadingLocation>
  <GoodsReceiptPlace>
    <ID>RSDVC</ID>
    <Name>2321</Name>
  </GoodsReceiptPlace>
  <TransshipmentLocation>
    <ID>CNAJG</ID>
  </TransshipmentLocation>
  <TransitDestination>
    <ID>CNAJG</ID>
  </TransitDestination>
  <RoutingCountryCode>AD</RoutingCountryCode>
  <GoodsConsignedPlace>
    <ID>CN15</ID>
  </GoodsConsignedPlace>
  <CustomsStatusCode>003</CustomsStatusCode>
  <FreightPayment>
    <MethodCode>PP</MethodCode>
  </FreightPayment>
  <ConsignmentPackaging>
    <QuantityQuantity>32</QuantityQuantity>
    <TypeCode>AM</TypeCode>
  </ConsignmentPackaging>
```

```
<TotalGrossMassMeasure>21212</TotalGrossMassMeasure>
<PreviousCustomsDocument>
  <ID>0100210293003</ID>
  <TypeCode>010</TypeCode>
</PreviousCustomsDocument>
<DeliveryDestination>
  <Line>fdsf</Line>
  <CityName>dsfs</CityName>
  <CountrySubEntityID>CN54</CountrySubEntityID>
  <CountrySubEntityName>dsf</CountrySubEntityName>
  <PostcodeID>100000</PostcodeID>
  <CountryCode>AE</CountryCode>
</DeliveryDestination>
<Handling>
  <InstructionsCodeCode>3</InstructionsCodeCode>
</Handling>
<IntermediateCarrier>
  <ID>fsdf</ID>
  <Communication>
    <ID>13644444444</ID>
    <TypeID>TE</TypeID>
  </Communication>
</IntermediateCarrier>
<Consignee>
  <ID>eqwe</ID>
  <Name>32</Name>
  <Address>
    <Line>1323</Line>
    <CityName>123</CityName>
    <CountrySubEntityID>CN32</CountrySubEntityID>
    <CountrySubEntityName>12312</CountrySubEntityName>
    <PostcodeID>300450</PostcodeID>
    <CountryCode>AF</CountryCode>
  </Address>
  <Communication>
    <ID>13611111111</ID>
    <TypeID>TE</TypeID>
  </Communication>
  <Contact>
    <Name>123</Name>
    <Communication>
      <ID>13611111111</ID>
      <TypeID>TE</TypeID>
    </Communication>
  </Contact>
</Consignee>
</Address>
</Communication>
</Contact>
</Communication>
```

```
</Contact>
</Consignee>
<Consignor>
  <ID>4335435</ID>
  <Name>fgsdg</Name>
  <Address>
    <Line>sdfs</Line>
    <CityName>dsfd</CityName>
    <CountrySubEntityID>CN22</CountrySubEntityID>
    <CountrySubEntityName>sdf</CountrySubEntityName>
    <PostcodeID>012600</PostcodeID>
    <CountryCode>AF</CountryCode>
  </Address>
  <Communication>
    <ID>13611111111</ID>
    <TypeID>TE</TypeID>
  </Communication>
</Consignor>
<NotifyParty>
  <ID>asad</ID>
  <Name>sfas</Name>
  <Address>
    <Line>dsfvds</Line>
    <CityName>fsdf</CityName>
    <CountrySubEntityID>CN15</CountrySubEntityID>
    <CountrySubEntityName>sdf</CountrySubEntityName>
    <PostcodeID>021400</PostcodeID>
    <CountryCode>AF</CountryCode>
  </Address>
  <Communication>
    <ID>1363333333</ID>
    <TypeID>TE</TypeID>
  </Communication>
</NotifyParty>
<UNDGContact>
  <Name>dfgfd</Name>
  <Communication>
    <ID>1365555555</ID>
    <TypeID>TE</TypeID>
  </Communication>
</UNDGContact>
<TransportEquipment>
  <EquipmentIdentification>
    <ID>WK040100001</ID>
```

```
</EquipmentIdentification>
<CharacteristicCode>22G1</CharacteristicCode>
<SupplierPartyTypeCode>3</SupplierPartyTypeCode>
<FullnessCode>4</FullnessCode>
<SealID AgencyCode="AC">M/123213</SealID>
</TransportEquipment>
<ConsignmentItem>
  <SequenceNumeric>1</SequenceNumeric>
  <ConsignmentItemPackaging>
    <QuantityQuantity>33</QuantityQuantity>
    <TypeCode>AM</TypeCode>
    <MarksNumbers>233</MarksNumbers>
  </ConsignmentItemPackaging>
  <Commodity>
    <CargoDescription>23</CargoDescription>
    <UNDGCode>0066</UNDGCode>
    <TariffClassificationCode>6209209090</TariffClassificationCode>
  </Commodity>
  <AdditionalInformation>
    <Content>23232</Content>
  </AdditionalInformation>
  <GoodsMeasure>
    <GrossMassMeasure>323</GrossMassMeasure>
  </GoodsMeasure>
  <EquipmentIdentification>
    <ID>WK040100001</ID>
  </EquipmentIdentification>
  <CustomsProcedure>
    <CurrentCode>4</CurrentCode>
  </CustomsProcedure>
  <UCR>
    <ID>3242433</ID>
  </UCR>
  <Origin>
    <OriginCountryCode>AF</OriginCountryCode>
  </Origin>
</ConsignmentItem>
</Consignment>
<Consignment>
  <TransportContractDocument>
    <ID>NFHA062800101</ID>
    <ConditionCode>27</ConditionCode>
    <Consolidator>
      <ID>32</ID>
```

```
</Consolidator>
</TransportContractDocument>
<AssociatedTransportDocument>
  <ID>NFHA06280010101</ID>
</AssociatedTransportDocument>
<GrossVolumeMeasure>232</GrossVolumeMeasure>
<ValueAmount CurrencyTypeCode="AED">232</ValueAmount>
<LoadingLocation>
  <ID>CNAJG/4201</ID>
  <LoadingDate>20170425133613</LoadingDate>
</LoadingLocation>
<UnloadingLocation>
  <ID>RSCBO</ID>
  <ArrivalDate>20170413</ArrivalDate>
</UnloadingLocation>
<GoodsReceiptPlace>
  <ID>RSDVC</ID>
  <Name>2321</Name>
</GoodsReceiptPlace>
<TransshipmentLocation>
  <ID>CNAJG</ID>
</TransshipmentLocation>
<TransitDestination>
  <ID>CNAJG</ID>
</TransitDestination>
<RoutingCountryCode>AD</RoutingCountryCode>
<GoodsConsignedPlace>
  <ID>CN15</ID>
</GoodsConsignedPlace>
<CustomsStatusCode>003</CustomsStatusCode>
<FreightPayment>
  <MethodCode>PP</MethodCode>
</FreightPayment>
<ConsignmentPackaging>
  <QuantityQuantity>32</QuantityQuantity>
  <TypeCode>AM</TypeCode>
</ConsignmentPackaging>
<TotalGrossMassMeasure>21212</TotalGrossMassMeasure>
<PreviousCustomsDocument>
  <ID>0100210293003</ID>
  <TypeCode>010</TypeCode>
</PreviousCustomsDocument>
<DeliveryDestination>
  <Line>fdsf</Line>
```

```
<CityName>dsfs</CityName>
<CountrySubEntityID>CN54</CountrySubEntityID>
<CountrySubEntityName>dsf</CountrySubEntityName>
<PostcodeID>100000</PostcodeID>
<CountryCode>AE</CountryCode>
</DeliveryDestination>
<Handling>
  <InstructionsCodeCode>3</InstructionsCodeCode>
</Handling>
<IntermediateCarrier>
  <ID>fsdf</ID>
  <Communication>
    <ID>1364444444</ID>
    <TypeID>TE</TypeID>
  </Communication>
</IntermediateCarrier>
<Consignee>
  <ID>eqwe</ID>
  <Name>32</Name>
  <Address>
    <Line>1323</Line>
    <CityName>123</CityName>
    <CountrySubEntityID>CN32</CountrySubEntityID>
    <CountrySubEntityName>12312</CountrySubEntityName>
    <PostcodeID>300450</PostcodeID>
    <CountryCode>AF</CountryCode>
  </Address>
  <Communication>
    <ID>1361111111</ID>
    <TypeID>TE</TypeID>
  </Communication>
  <Contact>
    <Name>123</Name>
    <Communication>
      <ID>1361111111</ID>
      <TypeID>TE</TypeID>
    </Communication>
  </Contact>
</Consignee>
<Consignor>
  <ID>4335435</ID>
  <Name>fgsdg</Name>
  <Address>
    <Line>sdfsf</Line>
```

```
<CityName>dsfd</CityName>
<CountrySubEntityID>CN22</CountrySubEntityID>
<CountrySubEntityName>sdf</CountrySubEntityName>
<PostcodeID>012600</PostcodeID>
<CountryCode>AF</CountryCode>
</Address>
<Communication>
  <ID>1361111111</ID>
  <TypeID>TE</TypeID>
</Communication>
</Consignor>
<NotifyParty>
  <ID>asad</ID>
  <Name>sfas</Name>
  <Address>
    <Line>dsfvds</Line>
    <CityName>fsdf</CityName>
    <CountrySubEntityID>CN15</CountrySubEntityID>
    <CountrySubEntityName>sdf</CountrySubEntityName>
    <PostcodeID>021400</PostcodeID>
    <CountryCode>AF</CountryCode>
  </Address>
  <Communication>
    <ID>1363333333</ID>
    <TypeID>TE</TypeID>
  </Communication>
</NotifyParty>
<UNDGContact>
  <Name>dfgfd</Name>
  <Communication>
    <ID>1365555555</ID>
    <TypeID>TE</TypeID>
  </Communication>
</UNDGContact>
<TransportEquipment>
  <EquipmentIdentification>
    <ID>WK04010001</ID>
  </EquipmentIdentification>
  <CharacteristicCode>22G1</CharacteristicCode>
  <SupplierPartyTypeCode>3</SupplierPartyTypeCode>
  <FullnessCode>4</FullnessCode>
  <SealID AgencyCode="AC">M/123213</SealID>
</TransportEquipment>
<ConsignmentItem>
```

```

<SequenceNumeric>1</SequenceNumeric>
<ConsignmentItemPackaging>
  <QuantityQuantity>33</QuantityQuantity>
  <TypeCode>AM</TypeCode>
  <MarksNumbers>233</MarksNumbers>
</ConsignmentItemPackaging>
<Commodity>
  <CargoDescription>23</CargoDescription>
  <UNDGCode>0066</UNDGCode>
  <TariffClassificationCode>6209209090</TariffClassificationCode>
</Commodity>
<AdditionalInformation>
  <Content>23232</Content>
</AdditionalInformation>
<GoodsMeasure>
  <GrossMassMeasure>323</GrossMassMeasure>
</GoodsMeasure>
<EquipmentIdentification>
  <ID>WK040100001</ID>
</EquipmentIdentification>
<CustomsProcedure>
  <CurrentCode>4</CurrentCode>
</CustomsProcedure>
<UCR>
  <ID>3242433</ID>
</UCR>
<Origin>
  <OriginCountryCode>AF</OriginCountryCode>
</Origin>
</ConsignmentItem>
</Consignment>
<AdditionalInformation>
  <Content>75432111</Content>
</AdditionalInformation>
</Declaration>
</Manifest>
</SWImpData>
</ImportMessage>

```

### 舱单导入成功回执示例：

```

<?xml version="1.0" encoding="UTF-8"?>
<Root>
  <resultFlag>1</resultFlag>
  <failCode/>

```



```

<failInfo/>
<retData>
  <?xml version="1.0" encoding="UTF-8"?>
  <Manifest>
    <Head>
      <MessageID>CN_MT2101_1p1_4201101115245_20170825103814102</MessageID>
      <FunctionCode>3</FunctionCode>
      <MessageType>MT2101</MessageType>
      <SenderID>4201101115245_SWS0000000001</SenderID>
      <ReceiverID>EPOR</ReceiverID>
      <SendTime>20170410095110147</SendTime>
      <Version>1.0</Version>
    </Head>
    <Response>
      <BorderTransportMeans>
        <JourneyID>NFHA0628006</JourneyID>
        <ID>YS0418</ID>
      </BorderTransportMeans>
      <Consignment>
        <TransportContractDocument>
          <ID>NFHA062800101</ID>
        </TransportContractDocument>
        <AssociatedTransportDocument/>
      </Consignment>
      <Consignment>
        <TransportContractDocument>
          <ID>NFHA062800101</ID>
        </TransportContractDocument>
        <AssociatedTransportDocument>
          <ID>NFHA06280010101</ID>
        </AssociatedTransportDocument>
      </Consignment>
    </Response>
  </Manifest>
</retData>
</Root>

```

### 舱单业务回执示例:

```

<?xml version="1.0" encoding="UTF-8"?>
<SWImpRep>
  <ResultFlag>1</ResultFlag>
  <FailCode/>
  <FailInfo/>
  <BizSeqNo>CN_MT2101_1p1_4201101115245_20170825103814102</BizSeqNo>

```

```
<BizType>MT2101</BizType>
<RetData>
  <Receipt>
    <Manifest>
      <Head>

<MessageID>CN_MT2101_1p1_4201101115245_20170825103814102</MessageID>
      <FunctionCode>3</FunctionCode>
      <MessageType>MT2101</MessageType>
      <SenderID>EPORT</SenderID>
      <ReceiverID>4201101115245_SWS0000000001</ReceiverID>
      <SendTime>20170825103614899</SendTime>
      <Version>1.0</Version>
    </Head>
    <Response>
      <BorderTransportMeans>
        <JourneyID>NFHA0628006</JourneyID>
        <ID>YS0418</ID>
      </BorderTransportMeans>
      <Consignment>
        <TransportContractDocument>
          <ID>NFHA062800101</ID>
        </TransportContractDocument>
        <ResponseType>
          <Code>01</Code>
          <Text>24301 预配舱单删除申请审核通过。</Text>
        </ResponseType>
      </Consignment>
      <Consignment>
        <TransportContractDocument>
          <ID>NFHA062800101</ID>
        </TransportContractDocument>
        <AssociatedTransportDocument>
          <ID>NFHA062800101</ID>
        </AssociatedTransportDocument>
        <ResponseType>
          <Code>01</Code>
          <Text>24301 预配舱单删除申请审核通过。</Text>
        </ResponseType>
      </Consignment>
    </Response>
  </Manifest>
</Receipt>
<Receipt>
```

```
<Manifest>
  <Head>

    <MessageID>CN_MT2101_1p1_4201101115245_20170825103814102</MessageID>

    <FunctionCode>3</FunctionCode>
    <MessageType>MT2101</MessageType>
    <SenderID>EPORT</SenderID>
    <ReceiverID>4201101115245_SWS0000000001</ReceiverID>
    <SendTime>20170825103614899</SendTime>
    <Version>1.0</Version>
  </Head>
  <Response>
    <BorderTransportMeans>
      <JourneyID>NFHA0628006</JourneyID>
      <ID>YS0418</ID>
    </BorderTransportMeans>
    <Consignment>
      <TransportContractDocument>
        <ID>NFHA062800101</ID>
      </TransportContractDocument>
      <ResponseType>
        <Code>01</Code>
        <Text>24301 预配舱单删除申请审核通过。</Text>
      </ResponseType>
    </Consignment>
    <Consignment>
      <TransportContractDocument>
        <ID>NFHA062800101</ID>
      </TransportContractDocument>
      <AssociatedTransportDocument>
        <ID>NFHA062800101</ID>
      </AssociatedTransportDocument>
      <ResponseType>
        <Code>01</Code>
        <Text>24301 预配舱单删除申请审核通过。</Text>
      </ResponseType>
    </Consignment>
  </Response>
</Manifest>
</Receipt>
</RetData>
</SWImpRep>
```

## 六、 地方口岸平台要求

提供地方单一窗口平台入口地址，要求统一地址。

如：广东单一窗口平台地址为：<http://test.singlewindow.gd.cn/>

应用根路径为 <http://test.singlewindow.gd.cn/index/swProxy/>

各业务应用地址为：

货物申报：

<http://test.singlewindow.gd.cn/index/swProxy/decserver/XXXX>

运输工具：

<http://test.singlewindow.gd.cn/index/swProxy/cdserver/XXXX>

舱单申报：

<http://test.singlewindow.gd.cn/index/swProxy/mftserver/XXXX>

则，提供给中央版为导入客户端进行的配置地址为

<http://test.singlewindow.gd.cn/index/swProxy/>

附：

1. 报关单回执，retData 节点里结构说明：（货物申报组提供，201708）

### 1.1 报关回执结构

序号	字段代码名称	字段中文名称	类型	说明
1	CUS_CIQ_NO	关检关联号	VARCHAR2 (18)	
2	ENTRY_ID	报关单编号	VARCHAR2 (18)	
3	NOTICE_DATE	通知时间	Date	
4	CHANNEL	回执代码	VARCHAR2 (1)	

5	NOTE	回执说明	VARCHAR2 (255)	
6	CUSTOM_MASTER	申报地海关	VARCHAR2 (4)	
7	I_E_DATE	进出口日期	Date	
8	D_DATE	申报日期	Date	

## 1.2 回执代码说明

海关回执定义	海关回执说明
L	海关入库回执
E	海关退单/不受理回执
G	海关接单交单回执
F	海关放行交单回执
W	海关无纸验放通知（审结）
I	海关无纸放行通知（放行）
C	海关无纸验放查验通知书（放行）
B	海关担保验放
P	海关已放行
P	海关已放行
R	海关已结关回执
H	海关挂起，需手工申报
M	海关重新审核通过
A	海关放行前删除或者异常处理（手工申报通知）
D	海关放行后删除
X	海关准予进港回执（上海洋山保税港区专用）

H (H883)	海关手工申报回执
Z (H883)	海关退回修改通知
T (H883)	海关税费通知
J	通关无纸化审结回执(审结回执一种)
N	补传随附单证电子数据
K	通关无纸化担保放行
7	申报成功
8	申报失败

## 2、联调测试环境地址

<http://updatetest.singlewindow.cn/SWClientUpdate/default.htm>